



INEOS | GRENADIER



FOREWORD

Written and visual depictions (including photographs, CGI and colors) of the Grenadier within this brochure maybe taken from European specification vehicles or prototypes and may vary from production models. Specifications and details may be subject to change without notice.

This brochure describes standard features, options and accessories. For further details on these items, please refer to pages 42– 45 of this Brochure or contact your INEOS Retail Partner.

Some of the features presented in this document may be optional in North America.





Jim Ratcliffe

“

A 4X4 NO-ONE'S BUILDING ANYMORE. THAT'S OUR BLUEPRINT FOR THE GRENADIER: A SERIOUSLY CAPABLE OFF-ROAD VEHICLE ENGINEERED TO FILL THE GAP.

”

Jim Ratcliffe

INTRODUCTION



Before we set out to create the Grenadier we listened to what you told us you wanted from a tough off-roader. Then found the best engineering partners for the job. And put our prototypes through punishing global testing for over 1.1 million miles. Quality, utility, durability, reliability, comfort: every detail's been thoroughly thought through then brought to life with expert precision.

Ladder frame chassis engineered by Magna, Springs by Eibach.

Award-winning drivetrain from BMW. Five-link beam axles from Carraro. Industry-leading gearbox by ZF. Off-road transfer case designed by us, made by Tremec. Seats by RECARO. Engineering excellence designed and tested to combine high performance with extreme utility. Able to tackle whatever task or terrain you have in mind. How you use it is down to you.





BUILT FOR EVERY DAY

BUILT FOR WORK



BUILT FOR OFF-ROAD

BUILT FOR THE WILD



BUILT FOR YOU



BUILT FOR EVERY DAY



INEOS | GRENADIER

BUILT FOR EVERY DAY

The Grenadier might be a rugged, reliable, uncompromising 4X4. But it's also so much more than that. It's comfortable. It's versatile. It's balanced to drive both on road and off. And it's designed to carry out whatever task your life throws at it.

So it's your family car, your vacation car, your weekend adventure car, the choice is yours. The 4X4 engineered for you to live with for many years to come.

“THE GRENADIER IS A UTILITARIAN THROWBACK WITH MODERN TOUCHES, MECHANICAL WHERE IT CAN BE BUT ELECTRONIC WHEREVER NECESSARY. FEWER ENGINE CONTROL UNITS EQUAL MORE SIMPLICITY.”

MERCEDES LILIENTHAL,
NEW YORK TIMES

*Aftermarket towing mirrors and trailer pictured are not offered by INEOS Grenadier.
Bull bar not available in North America.

TOWN AND COUNTRY

Gentle roads, quicker country lanes, out and about in town. Whatever speed you're traveling, or road conditions you're driving on, the Grenadier is highly responsive, well balanced, and fun to drive. The award-winning straight-six **3.0L turbo BMW engine** combined with the proven automatic **ZF transmission** give you the power and smooth multi-gear shifts to adapt effortlessly to any type of road. Tuned and calibrated together for great drivability and high torque at low revs. You can tow what you need, from camping trailers to horse trailers. And with permanent four-wheel-drive, you can trust the traction in any conditions. For those unexpected encounters, rely on the stopping power of the disks, pads and calipers of our **Brembo brake system**. Impressive, controlled performance that keeps you on the safe side. **Progressive Coil Springs** absorb those speed bumps and potholes. Added to the Grenadier's anti-roll bars and five-link suspension setup you can be sure of sharp, confident handling on sweeping bends. Handling you can feel. From the steering wheel to the road surface.

“WHEN YOU COMBINE ITS OFF-ROAD CAPABILITY WITH THE CLASS-LEADING PAYLOAD, YOU ARE REWARDED WITH A VEHICLE THAT IS READY TO TAKE YOU TO THE REMOTE CORNERS OF THE GLOBE, AND BACK AGAIN.”

SCOTT BRADY,
EXPEDITION PORTAL



GRAND TOURING

When you hit the highway, the Grenadier is a smooth, comfortable, and safe place to be. Cruise control on, a spacious and light cabin, supportive **Recaro seats** (heated if you need them)¹. All combine to help you go the distance. Got little ones on board? **Child seat anchor points** keeps them secure, while the tough **Utility Trim** is really easy to clean.

Long drives give you plenty of time to appreciate the small things. Those little details that can make even the longest journeys a pleasure. Enjoy extra character with our **Saddle Leather Driver's Pack**². And add supple full-grain **Leather Trim**³ and **Carpet Flooring**⁴ for extra comfort. Whether crossing a continent, tackling a lengthy commute, or taking a long-anticipated family trip, the Grenadier's interior is a great place from which to watch the miles go by.

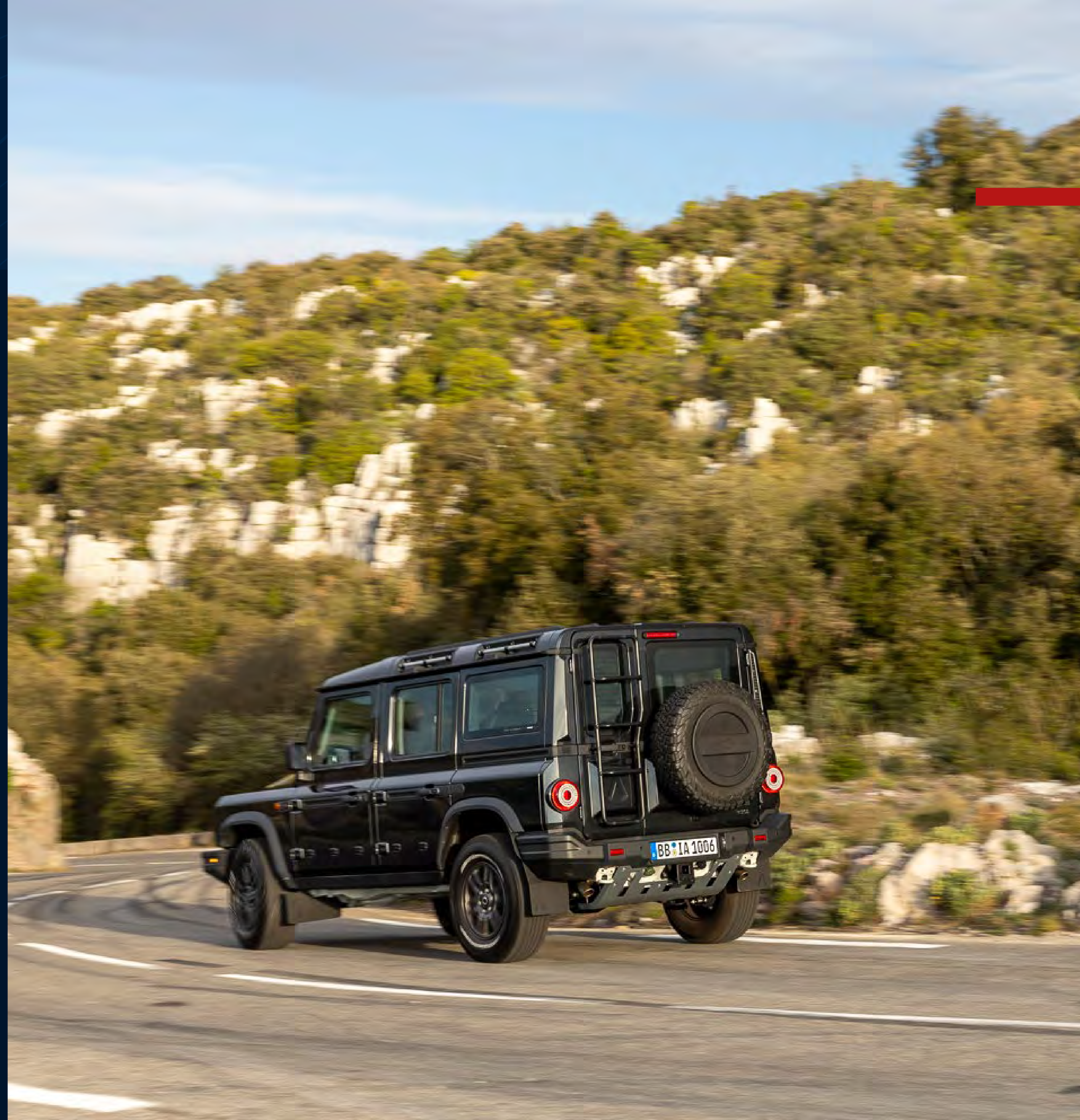

“**THROW IN AN EXCELLENT SET OF FRONT SEATS (RECAROS, BY THE WAY) AND THE DRIVE RESULTED IN FAR LESS FATIGUE THAN EXPECTED, MAKING IT A WELL-ROUNDED VEHICLE THAT YOU CAN DRIVE TO AND THROUGH THE TRAILS.**”

JONATHAN YARKONY,
DRIVING

¹Optional feature. Standard on Grenadier Fieldmaster Edition.

²Optional feature. Please note the important warranty terms and conditions relating to this option. See page 54.

³Optional feature. Standard/Available on Grenadier Fieldmaster Edition.

⁴Optional feature.

MOUNTAIN HIGH

The mountains are calling. You load the bikes, kayaks, climbing gear, skis. And head up the winding roads to adventure. With the commanding driving position, central instrument display and large mirrors, you enjoy excellent front and rear visibility.

Constantly aware of other road users, and with a clear view of the scenery on the way up. You alert a group of cyclists with a friendly press of the **Toot Button**. And after 1.1 million miles of global testing, including inside the Arctic circle, slippery snow on the

switchbacks is no problem, with **Permanent Four-Wheel Drive**, **ADAS** (Intelligent Speed Assistance, Lane Departure Warning, Automatic Emergency Braking, Driver Drowsiness Detection), **ABS** and **ESC** keeping you in charge at all times.



A TESTING
PROGRAMME
BUILT ON
PURPOSE.



BRIGHT LIGHTS

Shops, movies, restaurant, workplace. Wherever you're planning to pull up, make light work of heavy traffic with ECO Stop/Start. Have your favorite songs on tap thanks to **SiriusXM®¹** and our **Advanced Sound System⁴**. You can also easily access podcasts and playlists with **Android Auto™²** and wireless **Apple CarPlay®³**.

The INEOS Grenadier comes with a 3-month Platinum Plan trial subscription so you get the ultimate entertainment experience, featuring SiriusXM's expertly curated ad-free music and exclusive artist dedicated music channels, premium sports coverage with live play-by-play from every major sport, and sports talk including all of SiriusXM's official league and college conference channels. You also get Howard Stern, exclusive comedy, talk, and news. Discover even more when you stream on the SXM App, with Xtra music channels for any mood or activity, podcasts including SiriusXM originals, personalized Pandora stations and SiriusXM video including Howard Stern.

Need to check where you're meeting friends? Bluetooth connectivity and voice control means simple hands-free calls. Need a shortcut? Find it using Waze, Google Maps, or whatever app you choose. Maps, media, phonebook – it's all at your fingertips via the multifunction steering wheel, the **Central Control System's** easy to navigate touchscreen, or the **Rotary Controller**.

When you reach your destination, slot the Grenadier into the tightest of spaces using **Parking sensors** and the **Rear-View Camera**. Then head off safe in the knowledge the standard alarm or **Advanced Anti-theft Alarm and Immobilizer** is protecting your vehicle, wherever you parked.

Don't drive while distracted or while using handheld devices. Use voice-operated systems when possible. Not all features are compatible with all phones.

¹Vehicle will include 3-month trial subscription for SiriusXM. Your service will automatically stop at the end of your trial subscription unless you decide to continue service. See important information about SiriusXM on page 54.

²Vehicle user interface is a product of Google, and its terms and privacy statements apply. Requires appropriate Android phone, an active data plan and the Android Auto app. Google, Android and Android Auto are trademarks of Google LLC.

³Vehicle user interface is a product of Apple® and its terms and privacy statements apply. Requires compatible iPhone® and data plan rates apply. Apple CarPlay is a trademark of Apple, Inc.

⁴Optional feature. Standard on Grenadier Fieldmaster Edition.

BUILT FOR WORK





BUILT FOR WORK



Tough, capable, durable, and built to last. Engineered to get the job done, in all weather and terrain, year in, year out. Rest assured, the Grenadier is a working tool you can always rely on. Where you use it, how you use it, and what tasks you set; are up to you.

TOUGH TASKS

No matter how tough the site or working conditions the Grenadier won't let you down. Durable anti-corrosion protection for the ladder frame with E-coat, powder coating and hot wax treatment. Unique **30/70 Split Rear Doors** for quick and easy access in tight spaces, or with a trailer attached. Want to keep muddy things separate? Store gloves, ratchet straps, rain boots, or anything else in the handy **Spare Wheel Lockable Storage Box**¹.

For 70 cubic feet of loadspace in the Station Wagon, fold the **60:40 Split Folding Rear Bench Seats** flat. The **Interior Utility Rails**² and **Quick release Tie-Down rings**³ means everything has its place, so you can secure your gear and get on with the trip.

¹Optional feature.
²Optional feature. Standard on Grenadier Trialmaster Edition.
³Accessory. To be fitted by retailer partner. Not considered on the vehicle's CO2 calculation and subject to fitment price.



“THE INEOS GRENADIER LOOKS AND FEELS LIKE THE AUTHENTIC OFF-ROADER AND OVERLANDING RIG IT IS.”

CHRIS PAUKERT
EDMUNDS (US)



WOOD FOR THE TREES

Whatever the task, the Grenadier is your off-road office. Designed to get dirty, so no amount of mud, sawdust, or wet work clothes will stop you getting the job done. Clearly labeled, well-spaced buttons. The **Overhead Control Panel** keeping off-road switchgear out of the way. Pre-wired auxiliary switches or the **400W Power Take-Off¹** to power extra kit. Super supportive seats from renowned manufacturer **RECARO**. Utility, useability, and comfort, however long your working day. Tough, stain-, dirt, and waterresistant **Utility Trim**. Strong optional aluminum **Access Ladder²** to climb to the reinforced roof. Four **Roof Rails** to strap up to 220lb of gear. Four rubber Roof Strips that grip cargo and protect your paintwork. And 7,716 pound towing capacity* with **Trailer Stability Assist** as standard.

When the job's done, simply hose down the floor without worry thanks to the five drain valves and splashproof interior. The hard-wearing **Seat Covers³** offer even more protection.

¹Optional feature. Standard on Grenadier Trialmaster Edition.

²Optional feature. Standard on Grenadier Trialmaster and Fieldmaster Editions.

³Accessory. To be fitted by retailer partner. Not considered on the vehicle's CO2 calculation and subject to fitment price.

*Before you use the Grenadier for trawling, carefully review the towing section of the Grenadier Owner's Manual. The towing capacity of your Grenadier may vary. The weight of passengers, cargo and options or accessories may reduce the amount you can tow.



FULL RECOVERY

Whatever job you do, you need a 4X4 that won't let you down. For some, lives depend on it. That means durability and reliability is crucial. Comprehensive service schedule and online INEOS Customer Support Team. No matter where you operate, your Grenadier is always good to go.

Tailor yours any way you need to with **10- or 25- Amp pre-wiring** built in to easily add beacons, sirens, spotlights, and other exterior lighting. All switchable from the **Overhead Control Panel**. When the weather closes in, use the powerful **LED Light Bar*1** mounted to the **Roof Rack** or **Cross-bars*1**. When you need to, set about recovery with four heavy-duty **Towing Eyes**, and optional factory-installed, integrated, high-performance **Winch*1** for 12,125 pounds of winching power**.



“ **HAVING TRAVELLED TO A NEW NUMBER OF PROGRAMMES ALREADY WITH THE HALO TRUST (CAMBODIA, ZIMBABWE, UKRAINE AND NOW KOSOVO) IT'S CLEAR THAT THE GRENADIER WOULD BE UP FOR EVERY TERRAIN THAT WE OPERATE IN NOW AND IN THE FUTURE. IT'S EXTREMELY IMPORTANT THAT THE JOB THAT WE DO, WE CAN'T DO WITHOUT VEHICLES SO WE NEED A VEHICLE THAT WILL BE ABLE TO GET US THERE AND GET US BACK.** ”

PAUL BRADFORD
GLOBAL FLEET MANAGER,
THE HALO TRUST

*Accessory. To be fitted by retailer partner. Not considered on the vehicle's CO2 calculation and subject to fitment price.
**Please see full disclaimer on page 54.
** Before you use the Grenadier for winching, carefully review the winching section of the Grenadier Owner's Manual. The winching capacity of your Grenadier may vary.

BUILT FOR OFF-ROAD



Roof rack shown differs from final specification.

INEOS | GRENADIER



BUILT FOR OFF-ROAD



Slippery, deep, rutted, rocky. Off-road terrain comes in many forms. So, you need a 4X4 that's up to tackling every eventuality. With the Grenadier you have it, with some to spare. From power, torque, and grip, to rugged beam axles and constant traction, it's engineered for wherever you decide to take it. The ground underneath you may change, the Grenadier's capability does not.

“ THE GRENADIER
TURNS TRAILS
THAT'D MAKE
A HIKER
COLLAPSE
INTO A
NON-EVENT. ”

KYLE KINARD
ROAD AND TRACK (US)



*Optional feature. Standard on Grenadier Trialmaster Edition

MUD- SHEDDING

Slick or sticky, deep or swampy, you need to know your 4x4 can handle any surface. Our choice of Bridgestone All-Terrain or optional **BFGoodrich All-Terrain T/A KO2 tires*** means you're always prepared. **Permanent Four-Wheel-Drive** for reliable, instant traction. **ZF 8-speed automatic transmission** so you can keep your eyes on the trail and hands on the wheel. And seamless shifts to maintain momentum.

When the going gets really tough, drop the **Transfer Case** into low range and lock the center differential. Still in a bind? Check the steering angle and torque being sent to each wheel on the **Central Touchscreen**. And engage the individual front and rear differential switches for a full, three locking diff setup. All to keep moving even when only one wheel can develop traction.

DUNE RIDING

Taking on desert dunes is a true off-roading adventure. And for that you need the right tool. The Grenadier's traction control system takes shifting sand in its stride. Monitoring wheel slip and selectively applying brakes to regain traction. **Downhill Assist** keeps you on track on the way down. All the while, the **Raised Air Intake**¹ is sucking in clean air to help keep your filters clear, and your engine running at its best.

Sometimes you'll dig in. Drop the tire pressures and monitor them with the **TPMS** (Tire Pressure Monitoring System) on the central touchscreen. Add mounting options for shovels² and traction boards² so you'll have all the tools you need, when you need them. When dusk approaches but you want to carry on, toggle on the powerful **LED Auxiliary High Beam Lights** to illuminate the way ahead.



Roof rack shown differs from final specification.

¹Optional feature. Standard on Grenadier Trialmaster Edition.

²Accessory. To be fitted by retailer partner. Not considered on the vehicle's CO2 calculation and subject to fitment price.

ROCK SLIDING

Driving tough trails in a 4X4 takes commitment, grit, and skill. It also takes an off-road vehicle that can handle whatever you throw at it. Tough, capable, engineered without compromise, and built to last, we tested every aspect of the Grenadier in the harshest conditions. So you can get to grips with the roughest surfaces thanks to our rock solid **Two-speed Transfer Case**. A wheel at each corner that ensures short overhangs front and rear. Excellent ground clearance, approach and departure angles mean the steepest of slopes can be tackled with ease.

“THE SUSPENSION IS AN OFF-ROADER’S DREAM. YOU CAN SEE THE SOLID AXLE ABOVE, WITH A RATHER FLAT CENTER DIFFERENTIAL HOUSING, WHICH IS SOMETHING I DON’T THINK I’VE EVER SEEN ON A PRODUCTION VEHICLE. THAT’S NICE AND COMPACT AND HIGH OFF THE GROUND.”

DAVID TRACY,
THE AUTOPIAN

Strong, straightforward, coil sprung beam axles send power to the wheels for maximum wheel articulation and traction. Offering superior flex while maintaining grip to deal with the most uneven ground. The **Underride Protection** and **Rock Sliders*** ensure all your Grenadier’s essential components and bodywork stay protected.

Another pair of eyes is always helpful off road. The central touchscreen displays feedback so you’re always sure of your surroundings. Need fewer distractions? Activate Off-Road Mode to disable engine Start/ Stop, parking sensors and seatbelt reminder. Hitting deep water? Switch your engine fans off with **Wading Mode**.

BUILT FOR THE WILD



INEOS | GRENADIER



BUILT FOR THE WILD

You prepared for the trip. Plotted the route. Filled the gas tank and stowed the gear. Time to start your Grenadier and put the plan into action. Overlanding in Utah or spotting the big five in the Serengeti. Heading into the wilds to ski a glacier. Peddling a mountain or paddling a lake. Catching some waves. The Grenadier will get you and all your gear there and back again. However remote the destination.

THE ROAD LESS TRAVELLED

Heading off the beaten track isn't just about the destination, it's about the experience of getting there. With the Grenadier you're all set. Simply load up your gear and go. Activate the **Pathfinder** navigation* system and plot your own route, safe in the knowledge you're logging your journey, so you'll find your way back. A **Full-Size Spare Wheel** comes as standard too. Add the extra **Spare Wheel Bracket**¹ on the **Roof Rack**¹ to sling another wheel on the roof as backup for the backup.

There are loads of Roof Rack¹ attachments, so wherever you're heading, you can strap on whatever you want.

“ WE DIDN'T FIND ITS LIMITS ON A LONG OFF-ROAD TEST IN THE SCOTTISH HIGHLANDS, BUT IT WILL TAKE YOU FURTHER THAN YOU DARE GO. ”

BEN OLIVER
ROBB REPORT (USA)

¹Accessory. To be fitted by retailer partner. Not considered on the vehicle's CO2 calculation and subject to fitment price.
*Map coverage available for the United States and Canada.



ROOM, WITH A VIEW

Incredible wildlife. Spectacular landscapes. Memorable sporting moments. With seating for five and **40 cubic feet** of loadspace behind, pack the tripod, camp chairs and picnic box for the day ahead. And keep electronic items separate and safe in the **Underseat Dry Stowage**.

Parked up, chairs out, Tailgate Table down, you open the **Batwing Side Awning*** for 270

degrees of shelter. Pop the **Safari Windows*** out and there's a great viewpoint, perfect for cheering on the peloton during the Tour de France, watching wildlife, or checking out the surf. And if you do decide to head off into the wilderness on foot, keep valuables secure and out of sight in the **Lockable Central Stowage Box** for peace of mind.

THE HIGH ROAD

Ski touring, mountain biking, road bike climbs – when you need your mountain fix the Grenadier is ready. Winter or summer, simply load up your gear on the high strength, lightweight **Cross-bars*** and hit the heights. When the inside of the vehicle is full, stick extra clothes and gear in the weather-proof **Cargo Box***. Or use the roof to attach your bikes using the **Bike Carrier*** or skis and snowboards on the **Ski/Snowboard Carrier***.

“BEHIND THE SEATS, A SPLIT TAILGATE SWINGS OUT TO REVEAL THE LARGEST TRUNK OPENING I’VE EVER SEEN. IT’S CAVERNOUS.”

MATT BUBBERS,
TORONTO GLOBE & MAIL



BUILT FOR YOU

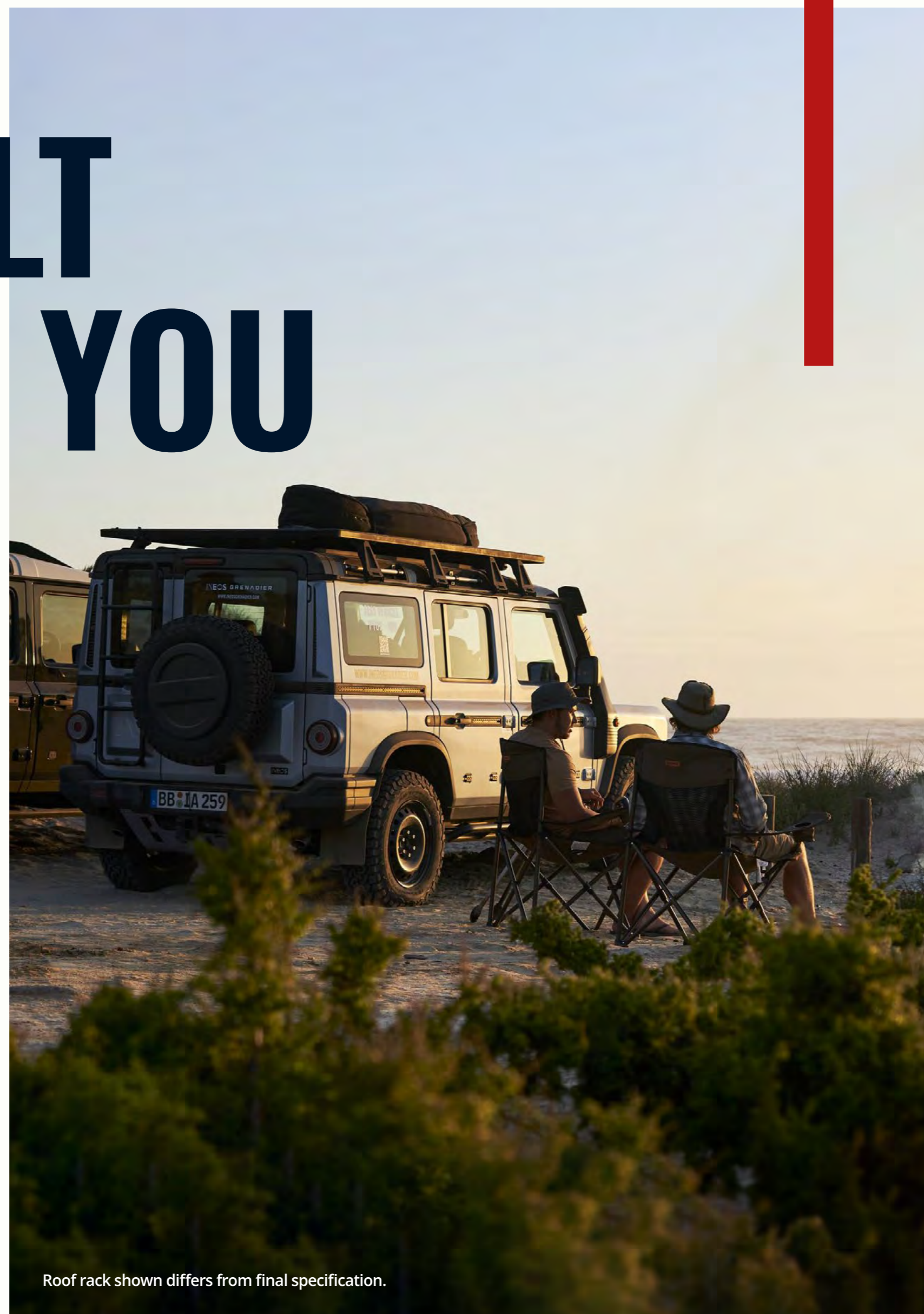

Roof rack shown differs from final specification.



INEOS | GRENADIER





BODY- STYLE

	STATION WAGON (5 SEAT)
BMW 3.0L Turbo Gasoline, Straight-Six Engine	^
8-Speed Automatic Transmission with Manual Override	^
Seats	5
Tie-Down Rings	10
Rear Side Windows	^

^ Standard
^ Available
^ Accessory

Computer-generated imagery.
 European spec vehicle shown with 17" Steel Wheels and BFGoodrich All-Terrain T/A KO2 tires.

STANDARD FEATURES

CHASSIS AND BODY

Full Box-Sectioned Ladder Frame

Galvanised Steel Body

Solid Beam Axles

Heavy Duty Coil Suspension

Two-Speed Transfer Case

Center Differential Lock

Hydraulic Power Steering

Disc Brakes Front and Rear

PERFORMANCE

BMW 3.0L Turbo Gasoline, Straight-Six Engine

8-Speed Automatic Transmission with Manual Override

Permanent Four-Wheel Drive

ECO Start/Stop

EXTERIOR

LED Headlights

LED Daytime Running Lights

LED Auxiliary High Beam Lights

LED Tail Lights

Home & Away Lighting

Underride Protection (Front, Rear and Fuel Tank Skidplates)

Towing Eyes (2 x Front, 2 x Rear)

30/70 Split Rear Doors

Side Bump Strips

Roof Protection Strips and Roof Rails

Heated Rear Window

WHEELS & TYRES

17" Steel Wheel

17" Bridgestone All-Terrain Tyre (265/70R17 XL 116S)

Full-Size Spare Wheel

Spare Wheel Cover

INTERIOR

Water Resistant Interior

Heavy Duty Utility Flooring with Drain Valves

Overhead Control Panel

Auxiliary Switch Panel & Electrical Preparation

Manually Adjustable Tilt & Telescopic Steering Wheel

One Touch Turn Signals

Front & Rear Electric Windows with One-Touch Auto Down

Interior Grab Handles

Automatic Climate Control

Second Row Air Vents

Loadspace Tie-Down Rings

Loadspace Stowage Locker

Underseat Dry Stowage

Glovebox

Centre Console Cup Holders (x2)

INFOTAINMENT AND CONNECTIVITY

12.3" LCD Colour Touchscreen

Central Control System

Rotary Controller

Pathfinder Off-Road Navigation

Wireless Apple CarPlay®

Android™ Auto

Bluetooth® Hands-Free Calling & Music Streaming

SiriusXM

Front & Rear USB Ports (x4)

Front & Rear 12V Sockets (x2)

SEATING AND TRIM

Utility Trim

RECARO Seats

Nappa Leather Driver's Pack

60/40 Split Folding Rear Bench Seat

Child Seat Anchor Points (ISOFIX / iSize)

SAFETY AND SECURITY

Toot Button

Front, Side, Knee and Curtain Airbags

Advanced Anti-Theft Alarm & Immobiliser

Remote Central Locking

Child Locks

ASSISTANCE SYSTEMS

Off-Road and Wading Modes

Uphill Assist

Downhill Assist

Park Assist Rear (PDC)

ESC (Electronic Stability Control)

ETC (Electronic Traction Control)

ABS (Anti-lock Braking System)

TPMS (Tyre Pressure Monitoring System)

Cruise Control

Automatic Hazard Warning

Trailer Stability Assist

Driver Assistance Systems (ADAS)

- Intelligent Speed Assistance
- Lane Departure Warning
- Automatic Emergency Braking
- Driver Drowsiness Detection

SMOOTH PACK

Rear-view Camera

Park Assist Front (PDC)

Power Heated Exterior Mirrors

Heated Windshield Washer Jets

Central Stowage Box, Lockable

Puddle Lamps and Ambient Door Lighting

Auxiliary Charge Points

ADDITIONAL EQUIPMENT

Vehicle Toolkit

Hydraulic Jack

GRENADIER X BELSTAFF

It's a story of momentum. For the launch of the Grenadier, we have teamed up with British outerwear specialist Belstaff, to bring two special editions of the vehicle – the Fieldmaster and the Trialmaster. Named after two of Belstaff's most iconic jackets, these no nonsense designs perfectly echo our own purpose-driven principles. Founded in 1924, Belstaff has a rich history of developing products envisaged for both function and progress: Protective suits for race-car drivers so they had the confidence to go faster. Windproofed smocks for Marines to help them weather any storm. Insulating

clothing for mountaineers so they could venture further. They have long been the chosen outfitter for independent spirits: from Amelia Earhart and T.E. Lawrence to Marlon Brando. Together, we share an appreciation of the journey there - wherever there might be.

GRENADIER |  BELSTAFF





THE TRIALMASTER

Cut from 6oz British Millerrain waxed cotton and featuring both a slanted map pocket and an ergonomic pivot shoulder for improved movement, the Trialmaster was created in 1948 at the request of professional Trials biker and Irishman, Sammy Miller. It remains a covetable classic to this day.



THE FIELDMASTER

Designed for life in the outdoors, the Trialmaster's younger brother has a roomier fit, cropped body and more modern, functional styling - perfect for a day's driving.

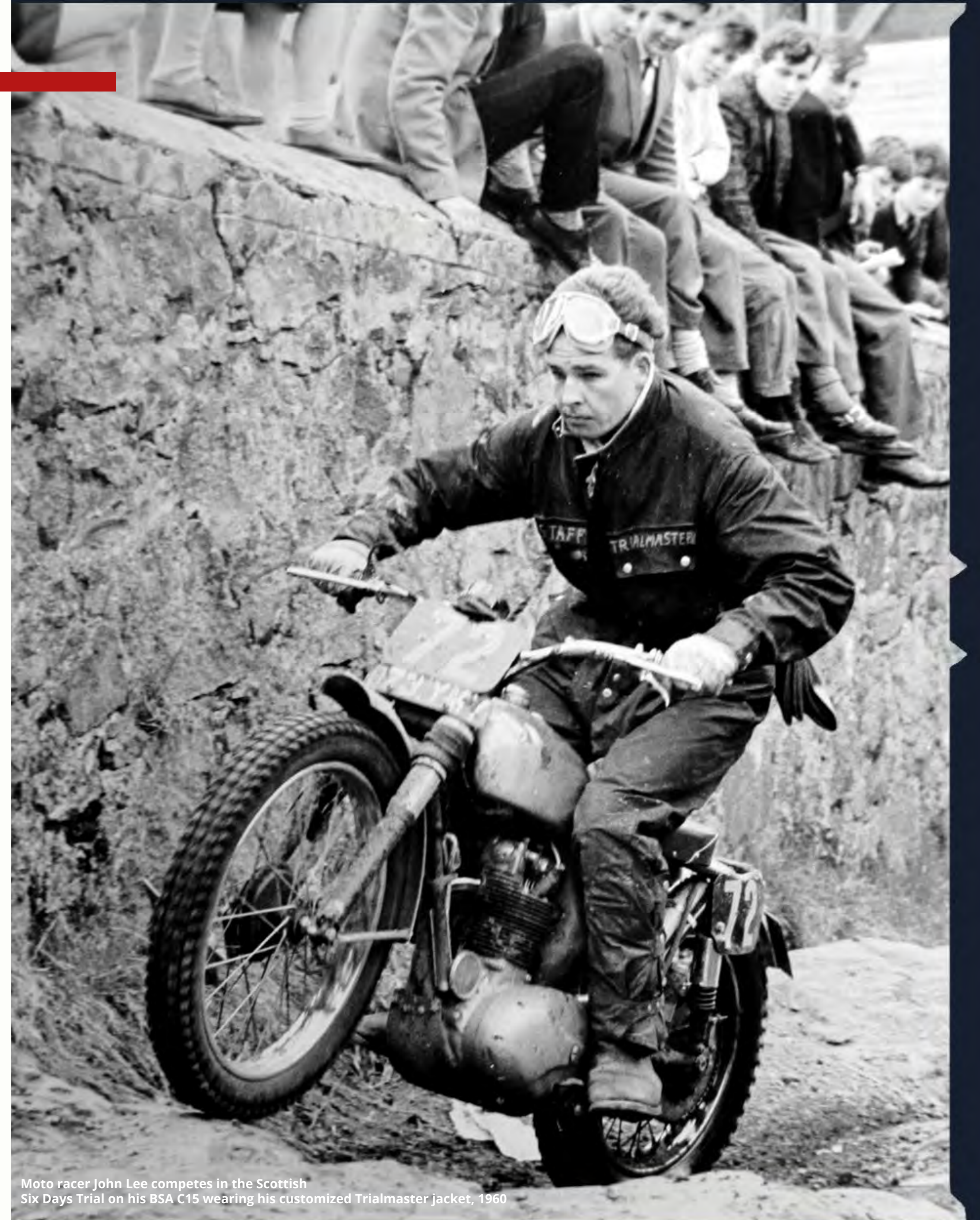

Moto racer John Lee competes in the Scottish Six Days Trial on his BSA C15 wearing his customized Trialmaster jacket, 1960

EDITIONS



GRENADIER

A blank canvas for you to configure to your exact needs. A stripped back, no nonsense workhorse that is Built on Purpose for the world..

European spec vehicles shown.
Computer-generated imagery.



GRENADIER TRIALMASTER

For the most extreme off-road conditions, the Grenadier Trialmaster Edition ensures there are no limits to your adventures.



GRENADIER FIELDMASTER

For exploration and escapism without a fixed destination. The Grenadier Fieldmaster Edition gives you the option of anywhere.

GRENADIER¹

Everything you need, nothing you don't.
Highly capable and adaptable, so you
can tailor it to your needs.

LHD Utility Wagon (5 seat) shown,
Vehicle shown in Magic Mushroom.
Computer-generated image.

¹All details which are provided should be considered only as
an indication, and may not reflect current specifications or
availability. Details provided do not constitute an offer for
the sale of any particular vehicle at any particular price or
specification.



GRENADIER

STANDARD FEATURES¹

BMW 3.0L, Turbo Gasoline, Straight-Six Engine

8-Speed Automatic Transmission with Manual Override

Permanent Four-Wheel Drive

Full Box-Sectioned Ladder Frame

Galvanised Steel Body

Carraro Beam Axles Front & Rear

Heavy Duty Coil Suspension

Two-Speed Transfer Case

Centre Differential Lock

Underride Protection (Front, Rear and Fuel Tank Skidplates)

LED Headlights

LED Auxiliary High Beam Lights

30/70 Split Rear Doors**

Full-Size Spare Wheel

Towing Eyes Front & Rear

Roof Rails & Roof Protection Strips

RECARO Seats

Central Control System

Overhead Control Panel

Toot Button

Off-Road & Wading Modes

Pathfinder Off-Road Navigation

Smooth Pack

Computer-generated image.

¹All details which are provided should be considered only as an indication, and may not reflect current specifications or availability. Details provided do not constitute an offer for the sale of any particular vehicle at any particular price or specification.





GRENADIER TRIALMASTER EDITION¹

The Trialmaster Edition has been specified with extreme off-roading in mind. Whatever the terrain, the front and rear differential locks, BFGoodrich All-Terrain tires, and raised air intake will keep you going. Secure your gear with the exterior utility belt or interior utility rails. And for plug and play capability, power up your equipment with the high load auxiliary switch panel and auxiliary battery.

EXTERIOR* FEATURES

17" Steel Wheels

Raised Air Intake

Exterior Utility Belt

Access Ladder

Rough Pack:

- Differential Locks Front & Rear
- BFGoodrich All-Terrain T/A KO2 tyres

*In addition to Grenadier Standard Equipment.

LHD vehicle shown in Sela Green.
Computer-generated image.

¹ All details which are provided should be considered only as an indication, and may not reflect current specifications or availability. Details provided do not constitute an offer for the sale of any particular vehicle at any particular price or specification.





GRENADIER TRIALMASTER EDITION¹

INTERIOR* FEATURES

Interior Utility Rails

Auxiliary Battery

High Load Auxiliary Switch Panel & Electrical Preparation

Compass with Altimeter

Power Take Off, 400W

*In addition to Grenadier Standard Equipment.

Computer-generated image.

¹All details which are provided should be considered only as an indication, and may not reflect current specifications or availability.

Details provided do not constitute an offer for the sale of any particular vehicle at any particular price or specification.

INEOS | GRENADIER





GRENADIER FIELDMASTER EDITION¹

The Fieldmaster Edition has been specified for all of your adventures, on- and off-road. It brings comfort, style and refinement with interior leather, carpet floor mats and 18" alloy wheels. The heated front seats will keep you warm on cold days. And when the suns out, pop up or completely remove the safari windows for an open-air experience.

EXTERIOR* FEATURES

- 18" Alloy Wheels
- Locking Wheel Nuts
- Safari Windows
- Access Ladder

*In addition to Grenadier Standard Equipment.

Computer-generated image.

¹All details which are provided should be considered only as an indication, and may not reflect current specifications or availability. Details provided do not constitute an offer for the sale of any particular vehicle at any particular price or specification





GRENADIER FIELDMASTER EDITION¹

INTERIOR* FEATURES

Leather Trim (Black or Grey/Black)

Heated Front Seats

Carpet Floor Mats

Compass with Altimeter

Premium Sound System



*In addition to Grenadier Standard Equipment.

Computer-generated image.

¹All details which are provided should be considered only as an indication, and may not reflect current specifications or availability.

Details provided do not constitute an offer for the sale of any particular vehicle at any particular price or specification.

SOLID



SCOTTISH WHITE



MAGIC MUSHROOM



ELDORET BLUE



BRITANNIA BLUE



SELA GREEN



INKY BLACK

METALLIC



STERLING SILVER



SHALE BLUE



QUEEN'S RED



DONNY GREY

CONTRAST ROOF - PAINTED



SCOTTISH WHITE



INKY BLACK

CONTRAST LADDER FRAME - POWDER COAT



BLACK



RHINO GREY*



HALO RED*

* For each HALO Red and Rhino Grey optional ladder from finish sold, INEOS Automotive will donate €150 to the respective organizations that inspired the name of the colors. "Rhino Grey" recognizes INEOS Automotive's support for The Rhino Orphanage in South Africa, while "HALO Red" celebrates the company's development partnership with The Halo Trust.

WHEELS

17" STEEL



18" STEEL



17" ALLOY



18" ALLOY



TYRES

BRIDGESTONE ALL - TERRAIN TYRE



17" RIM - 265/70R17 XL 116S
18" RIM - 255/70R18 XL 116S

BFGOODRICH ALL - TERRAIN T/A K02 TYRE



17" RIM - LT265/70R17 121/118S
18" RIM - LT255/70R18 117/114S

DRIVER'S PACK

NAPPA LEATHER



SADDLE LEATHER*



INTERIOR TRIM

UTILITY TRIM

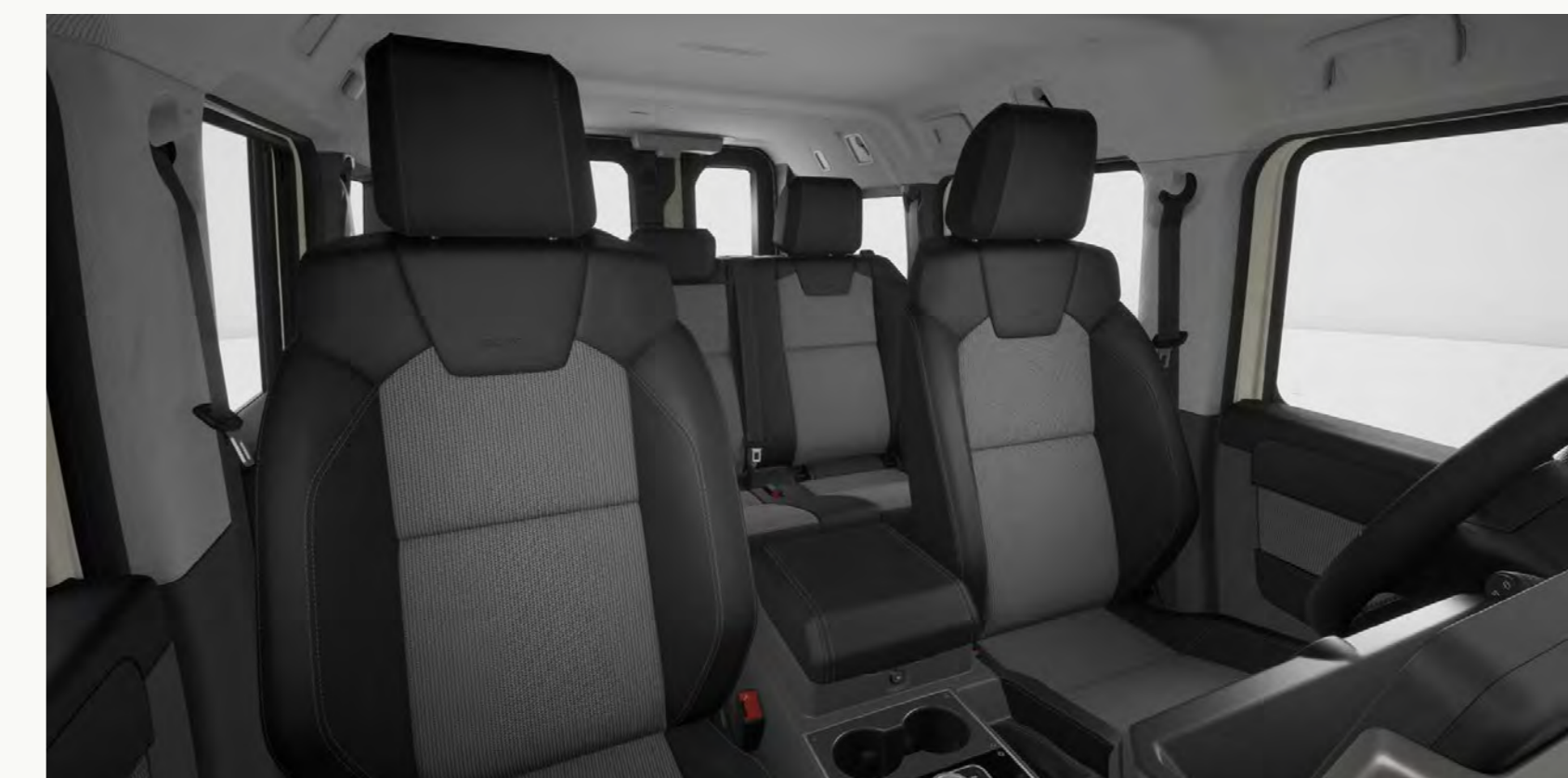

LEATHER TRIM - BLACK



LEATHER TRIM - GREY/BLACK



*Please note the important warranty terms and conditions relating to this option. See page 54.

ACCESSORIES

Interior. Exterior, whatever the task, journey or adventure. Our complete set of accessories means you're ready. Available for purchase and installation at INEOS Grenadier Retail Partners.

EXTERIOR

- Side Runners
- Rock Sliders
- LED Light Bar*
- Locking Wheel Nuts
- Cyclone Pre-Cleaner
- Checker Plates
- National Flag Plaque
- Removable Rear Winch
- Recovery Kit

INTERIOR

- Rubber Floor Mats
- Carpet Floor Mats
- Seat Covers – Front
- Seat Covers – Rear
- Tailgate Table
- Loadspace Partition Net
- Luggage Organiser
- Luggage Net
- Quick Release Tie-Down Rings (x4)

UP TOP

- Cross-Bars
- Spare Wheel Carrier
- Hi-Lift Jack Mount
- Load Corner Brackets
- Surfboard Carrier
- Tool Bracket
- Roof Rack
- Sand Ladder Flat Mounting Brackets
- Batwing Side Awning
- Work Lamp Bracket
- Folding Aerial Mount
- Roof Tie-Down Rings
- Lockdown Security Cable
- Cargo Load Straps
- Cargo Box
- Kayak Mounts, Saddles
- Kayak Mounts, J-Style
- Bike Carrier
- Ski/Snowboard Carrier
- Adjustable Load Carrier
- Heavy Duty Shovel



*Please see full disclaimer on page 54.
When used herein, "Retail Partner" shall mean any INEOS authorized dealer, repairer or service provider.

EXTERIOR OPTIONS AND ACCESSORIES

EDITIONS

	GRENADIER	GRENADIER TRIALMASTER	GRENADIER FIELDMASTER
BODY COLOUR			
SOLID PAINT			
Scottish White	^	^	^
Magic Mushroom	^	^	^
Eldoret Blue	^	^	^
Britannia Blue	^	^	^
Sela Green	^	^	^
Inky Black	^	^	^
METALLIC PAINT			
Sterling Silver	^	^	^
Shale Blue	^	^	^
Queen's Red	^	^	^
Donny Grey	^	^	^
CONTRAST ELEMENTS			
CONTRAST ROOF - PAINTED			
Scottish White (Solid)	^	^	^
Inky Black (Solid)	^	^	^
CONTRAST FRAME - POWDER COAT			
Black	^	^	^
HALO Red*	^	^	^
Rhino Grey*	^	^	^

EDITIONS

	GRENADIER	GRENADIER TRIALMASTER	GRENADIER FIELDMASTER
WHEELS			
17" Steel Wheel	^	^	-
18" Steel Wheel	^	^	-
17" Alloy Wheel	^	^	-
18" Alloy Wheel	^	^	^
Locking Wheel Nuts	^	^	^
TYRES			
Bridgestone All-Terrain Tyre	^	-	^
BFGoodrich All-Terrain T/A KO2 Tyre	^	^	^
ADDITIONAL EXTERIOR FEATURES			
Access Ladder	^	^	^
Side Runners	^	^	^
Bump Strips	^	-	^
Exterior Utility Belt**	^	^	^
Safari Windows	^	^	^
Heat Reflective Privacy Glass	^	^	^
Rear Side Windows	^	^	^
Checker Plates	^	^	^
Spare Wheel Cover	^	^	^
Spare Wheel Lockable Storage Box	^	^	^
National Flag Plaque	^	^	^

^ Standard ^ Available ^ Option ^ Accessory

*For each HALO Red and Rhino Grey optional ladder from finish sold, INEOS Automotive will donate €150 to the respective organizations that inspired the name of the colors. "Rhino Grey" recognizes INEOS Automotive's support for The Rhino Orphanage in South Africa, while "HALO Red" celebrates the company's development partnership with The Halo Trust.

**Restricted usage on-road dependent on local laws.

Note that some standard features may be replaced when specifying a vehicle or selecting trim levels. Certain features have a limited warranty, please refer to the INEOS Automotive Manufacturers Warranty Terms and Conditions for all exceptions. All details which are provided should be considered only as an indication, and may not reflect current specifications or availability. Details provided do not constitute an offer for the sale of any particular vehicle at any particular price or specification.

INTERIOR, UTILITY OPTIONS AND ACCESSORIES

	EDITIONS		
	GRENADIER	GRENADIER TRIALMASTER	GRENADIER FIELDMASTER
SEATING			
Utility Trim	^	^	-
Leather Trim - Black	^	^	^
Leather Trim - Grey/Black	^	^	^
Heated Front Seats	^	^	^
Seat Covers – Front	^	^	^
Seat Covers – Rear	^	^	^
COMFORT			
Nappa Leather Driver's Pack	^	^	^
Saddle Leather Driver's Pack*	^	^	^
INFOTAINMENT			
Premium Sound System	^	-	^

	EDITIONS		
	GRENADIER	GRENADIER TRIALMASTER	GRENADIER FIELDMASTER
PACKS			
ROUGH PACK - Differential Locks Front & Rear - BFGoodrich All-Terrain T/A KO2	^	^	^
FLOORING			
Heavy Duty Utility Flooring with Drain Valves	^	^	^
Carpet Flooring	^	^	^
Rubber Floor Mats	^	^	^
Carpet Floor Mats	^	^	^

^ Standard ^ Available ^ Option ^ Accessory

All details which are provided should be considered only as an indication, and may not reflect current specifications or availability. Details provided do not constitute an offer for the sale of any particular vehicle at any particular price or specification.

*Please note the important warranty terms and conditions relating to this option. See page 54.

Note that some standard features may be replaced when specifying a vehicle or selecting trim levels. In car features should only be used when safe to do so. Certain features have a limited warranty, please refer to the INEOS Automotive Manufacturers Warranty Terms and Conditions for all exceptions.

UTILITY OPTIONS AND ACCESSORIES

EDITIONS

	GRENADIER	GRENADIER TRIALMASTER	GRENADIER FIELDMASTER
OFF-ROAD CAPABILITY			
Centre Differential Lock	^	^	^
Differential Locks Front & Rear	^	^	^
Underride Protection	^	^	^
Raised Air Intake	^	^	^
Cyclone Pre-Cleaner	^	^	^
Rock Sliders	^	^	^
LED Lightbar*	^	^	^
WINCHING & TOWING			
Integrated Heavy Duty Winch - 5.5T	^	^	^
Removable Rear Winch	^	^	^
Recovery Kit	^	^	^
Heavy Duty Shovel	^	^	^
Class III 2" NAS Tow Hitch & Electrics	^	^	^
Towing Mounting Plate (Front)	^	^	^
POWER			
Auxiliary Battery	^	^	-
High Load Auxiliary Switch Panel & Electrical Preparation	^	^	^

EDITIONS

	GRENADIER	GRENADIER TRIALMASTER	GRENADIER FIELDMASTER
INTERIOR CARGO			
Interior Utility Rails	^	^	^
Tailgate Table	^	^	^
Luggage Organiser	^	^	^
Loadspace Partition Net	^	^	^
Luggage Net	^	^	^
Quick Release Tie-down Rings	^	^	^
SAFETY, SECURITY & CONVENIENCE			
Advanced Anti-Theft Alarm & Immobiliser	^	^	^
Park Assist Rear (PDC)	^	^	^
Roadside Emergency Kit	^	^	^
Roadside Emergency Kit Plus	^	^	^
Smokers Pack	^	^	^
Compass with Altimeter	^	^	^

^ Standard ^ Available ^ Option ^ Accessory

*Please see full disclaimer on page 54.
Note that some standard features may be replaced when specifying a vehicle or selecting trim levels. In car features should only be used when safe to do so. Before towing or winching consult the Owner's Manual or your closest Retail Partner for more detail. Off-road driving and related equipment requires advanced training and experience and may result in property damage and/or injury. Always check vehicle, route and conditions ahead before proceeding. When used herein, "Retail Partner" shall mean any INEOS authorized dealer, repairer or service provider.

UTILITY OPTIONS AND ACCESSORIES

	EDITIONS		
	GRENADIER	GRENADIER TRIALMASTER	GRENADIER FIELDMASTER
ROOF CARGO			
Roof Rack	^	^	^
Cross-bars	^	^	^
Spare Wheel Carrier	^	^	^
Hi-Lift Jack Mount	^	^	^
Load Corner Brackets	^	^	^
Surfboard Carrier	^	^	^
Tool Bracket	^	^	^
Roof Tie-down Rings	^	^	^
Sand Ladder Flat Mounting Brackets	^	^	^
Work Lamp Bracket	^	^	^
Folding Aerial Mount	^	^	^
Batwing Side Awning	^	^	^
Lockdown Security Cable	^	^	^
Cargo Load Straps	^	^	^
Cargo Box	^	^	^
Kayak Mount - Saddles	^	^	^
Kayak Mount - J-Style	^	^	^
Bike Carrier	^	^	^
Ski/Snowboard Carrier	^	^	^
Pioneer Accessory Bar	^	^	^

^ Standard ^ Available ^ Option ^ Accessory

Note that some standard features may be replaced when specifying a vehicle or selecting trim levels. Additional accessories may affect exterior dimensions and off-road geometry. In car features should only be used when safe to do so. Note loading equipment onto the Full-length Roof Rack or Roof Cross-bars may change the vehicles handling characteristics.

PERFORMANCE

PETROL

POWERTRAIN

Engine	BMW B58
Cylinders and Layout	6 (Straight)
Valves	24 (DOHC)
Fuel Delivery	Direct Injection
Displacement [cu.in]	182.9
Cylinder Bore x Stroke ["]	3.2 x 3.7
Compression Ratio	11.0:1
Maximum Power [BHP]	282 (4,750 rpm)
Maximum Torque [lb.ft]	332 (1,750-4,000 rpm)
Transmission	ZF 8HP51
Number of Gears (automatic)	8
Transfer Case Ratio	2.5:1

PERFORMANCE

Maximum Speed [mph]	99
Acceleration: 0-62mph [s]	8.8

SUSPENSION AND BRAKES

Front Suspension	5-Link with Coil Springs
Rear Suspension	5-Link with Coil Springs
Front Axle	Solid Beam
Rear Axle	Solid Beam
Front Brakes	Ventilated Disc
Rear Brakes	Solid Disc
Front Brake Disc Diameter ["]	12.4
Rear Brake Disc Diameter ["]	12
Front Calipers	Twin Piston
Rear Calipers	Single Piston

STEERING

Steering System	Hydraulically Assisted Power Steering
Turning Circle (kerb-kerb) [ft]	44.3

UTILITY/STATION WAGON

FUELLING

Recommended Fuel Quality [Pump Octane Number]	91
Minimum Fuel Quality [Pump Octane Number]	87
Fuel Capacity [gal]	23.7

GASOLINE

STATION WAGON

STATION WAGON - FIELDMASTER

STATION WAGON - TRIALMASTER

GASOLINE

GASOLINE

GASOLINE

FUEL ECONOMY EPA*

Fuel Economy City [mpg]	15	15	14
Fuel Economy Highway [mpg]	15	15	14
Fuel Economy Combined [mpg]	15	15	14

All details which are provided should be considered only as an indication, and may not reflect current specifications or availability. Details provided do not constitute an offer for the sale of any particular vehicle at any particular price or specification.

*All values are in US mpg. Preliminary data subject to change. Final fuel economy values will be published prior to launch.

Always obey local speed limits.

STATION / UTILITY WAGON EXTERIOR DIMENSIONS

EXTERIOR DIMENSIONS	STATION WAGON
Length (including spare wheel) ["]	191.2
Width with Mirrors ["]	84.5
Width without Mirrors ["]	76
Vehicle Height ["]*	80.7
Track Width ["]	64.8
Front Overhang ["]	33.4
Rear Overhang ["]	34.4
Wheelbase ["]	115

OFF-ROAD GEOMETRY*	STATION WAGON
Ground Clearance ["]	10.4
Approach Angle [°]	36.2
Ramp Breakover Angle [°]	28.2
Departure Angle [°]	36.1
Gradeability [°]	45
RTI (20° Ramp)**	585
Wading Depth ["]	31.5
Front Axle Articulation [°]	9
Rear Axle Articulation [°]	12



KEY

Approach Angle	A
Departure Angle	B
Ramp Breakover Angle	C
Ground Clearance	D
Wading Depth	E

*Measured at Curb Weight.

**Dependent on vehicle load.

All details which are provided should be considered only as an indication, and may not reflect current specifications or availability. Details provided do not constitute an offer for the sale of any particular vehicle at any particular price or specification. European vehicle shown.

Off-road driving requires advanced training and experience and may result in property damage and/or injury. Always check vehicle, route and conditions ahead before proceeding.

Additional accessories may affect Exterior Dimensions and Off-road geometry.

LOADING CAPACITY

STATION WAGON – 5 SEAT

GASOLINE

WEIGHTS

Gross Vehicle Weight [lbs]	7,716
Kerb Weight (without driver) [lbs]*	5,875
Maximum Payload (without driver) [lbs]*	1,841
Dynamic Roof Load [lbs]**	330
Static Roof Load [lbs]**	925
Maximum Unbraked Trailer Mass (on-road) [lbs]	1,653
Maximum Braked Trailer Mass (on-road) [lbs]	7,716
Maximum Trailer Nose Weight [lbs]	771
Gross Train Weight [lbs]	15,432

LOADSPACE

Maximum Volume behind 1st Row [cu.ft]	71.8
Maximum Volume behind 2nd Row [cu.ft]	40.6
Maximum Luggage Length behind 1st Row ["]	64.7
Maximum Luggage Length behind 2nd Row ["]	31.4
Floor Length behind 1st Row ["]	70.6
Floor Length behind 2nd Row ["]	38.7
Loadspace Width (floor between wheel-arches) ["]	41.8
Maximum Loadspace Width ["]	49.9
Lift in Height ["]	35.3
Loadspace Height ["]	41.2

INTERIOR DIMENSIONS

Maximum Front Headroom ["]	39.4
Maximum Rear Headroom ["]	39.4
Maximum Front Legroom ["]	39.3
Maximum Rear Legroom ["]	30.4

*90% Fuel and all liquids (no driver).

**With Full Length Roof Rack (Roof Rack weight not included). Maximum 100kg Static Load without Roof Rack or Cross-bars.

All details which are provided should be considered only as an indication, and may not reflect current specifications or availability.

Details provided do not constitute an offer for the sale of any particular vehicle at any particular price or specification.

Do not load vehicle beyond its intended capacities, note loading equipment on the roof may change the vehicles handling characteristics.

Before towing consult the Owner's Manual or your closest Retail Partner for more detail.

When used herein, "Retail Partner" shall mean any INEOS authorized dealer, repairer or service provider.

FINANCE

FINANCE

Our dealership network throughout North America is there when you need expert advice or are ready for a test drive. We have chosen our dealer partners because they really “get” off-road vehicles. All of our dealers are trained and supported by our own technical teams and INEOS Automotive HQ. You can find your nearest dealer with our [online map](#).

INEOS Automotive Finance offers a variety of lease and retail finance options for Grenadier customers who prefer not to pay cash at the time of purchase. Get customizing through our [online configurator](#).

LEASE

Leasing through INEOS Automotive Finance provides flexible terms and mileage options to meet your requirements. Monthly lease payments are typically lower than retail finance payments when compared over the same term, offering financial flexibility.

RETAIL FINANCE

Financing through INEOS Automotive Finance means no mileage limitations on your vehicle and allows for enhancements or modifications to your Grenadier that you might desire. Financing can also spread the cost of your Grenadier over a period that is appropriate for your needs.



When used herein, “Retail Partner” shall mean any INEOS authorized dealer, repairer or service provider.

For more information, visit our [how to buy webpage](#).



SERVICING

Regular service by INEOS-trained technicians is available at our Retailer Partners and authorized service providers. It is our aim to develop a comprehensive and expansive service network in order to support you, wherever your Grenadier may take you.

LIMITED WARRANTY

Durability and reliability are core to the Grenadier's DNA. We're confident in the engineering and we've proven the vehicle's capability and quality over 1.1 million miles. Backed by our comprehensive new vehicle limited warranty.

PARTS

We know waiting for parts can be an inconvenience. So we are developing an extensive parts network supported by regional hubs and logistics partners.

OVERVIEW

Manufacturer's Limited Warranty ¹	3 Years - 60,000 miles
Limited Paint Warranty ²	3 Years - 60,000 miles
Limited Whole Vehicle Anti-Perforation ³	12 Years
Accessories	3 Years

¹INEOS will warrant each 2024 Grenadier for 5-years/60,000 miles (whichever comes first; see dealer for details), from the original in-service date of the vehicle, for warrantable repairs that are required as a result of defects due to materials and/or workmanship.

²Paint coverage covers any repairs, replacements, or adjustments needed to correct defects in materials or workmanship for original factory paint for 3 years/60,000 miles (whichever comes first; see dealer for details) from the original in-service date of the vehicle.

³The Anti-Perforation coverage covers any repairs, replacements, or adjustments of the body sheet metal panels and the chassis frame on a vehicle that suffer from inside-to-outside perforation from corrosion as a result of defective materials or workmanship for 12 years from the original in-service date of the vehicle. The coverage, however, requires that the Covered Vehicle is inspected, and repaired, if necessary, annually by an INEOS Automotive Approved Workshop.

JOIN OUR SQUADRON

Forging a new path doesn't mean travelling alone. Join our Squadron, our insider community of drivers, and get early access to new products and curated experiences. Secure exclusive access to Grenadier off-road events. Get new merchandise, accessories and upgrades before they become available. And go behind the scenes of this purpose built 4X4.



THE RIGHT PRODUCTION SITE

From the off, we've understood what you need from your Grenadier. A rugged, capable off-roader designed to tackle the toughest of tasks. A 4x4 assembled by experts with the uncompromising build quality and engineering excellence you expect. And a vehicle built to last in a technically advanced facility. We invested an extra \$50m in a new paintshop, fully automated bodyshop, and quality center at our

state-of-the-art factory in Hambach, France. Now we have 2.3million sqf housing 1,000 highly experienced workers with an excellent reputation for quality. And 20,000 hours of Grenadier-specific training under their belts. First they produced production prototypes, now they're on the line making Grenadiers for you.



“ IN HAMBACH WE’VE ACQUIRED THE IDEAL FACILITY, WITH ALL THE EXPERTISE AND ENGINEERING EXCELLENCE WE NEED TO PRODUCE THE QUALITY VEHICLES WE’VE SET OUT TO BUILD. ”

LYNN CALDER
CEO, INEOS AUTOMOTIVE

DRIVER ASSISTANCE

DRIVER SYSTEMS

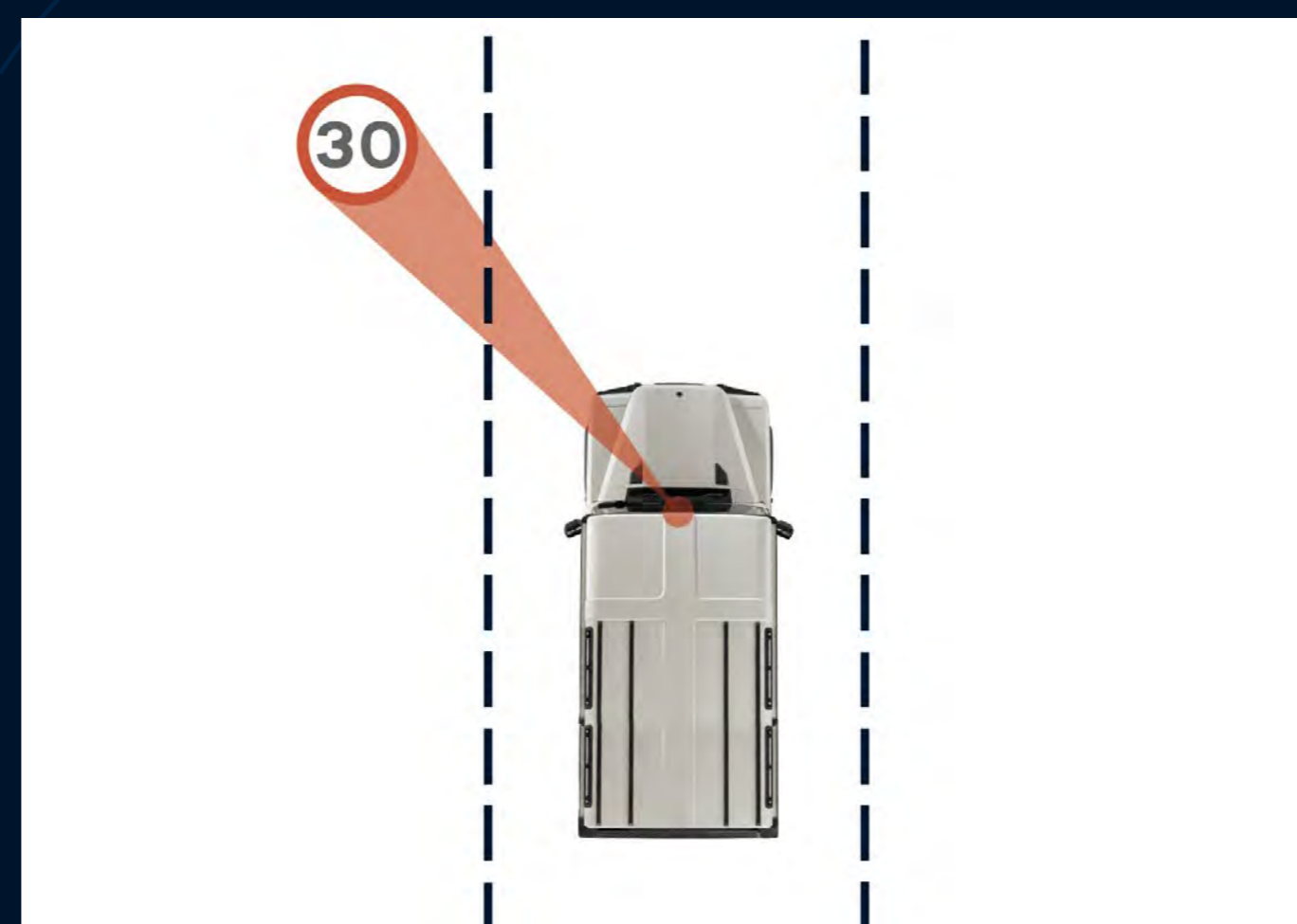

INTELLIGENT SPEED ASSISTANCE

Assists drivers in adhering to the speed limit. The vehicle takes speed information from maps and traffic signs, notifying the driver when they are above the prescribed speed limit.

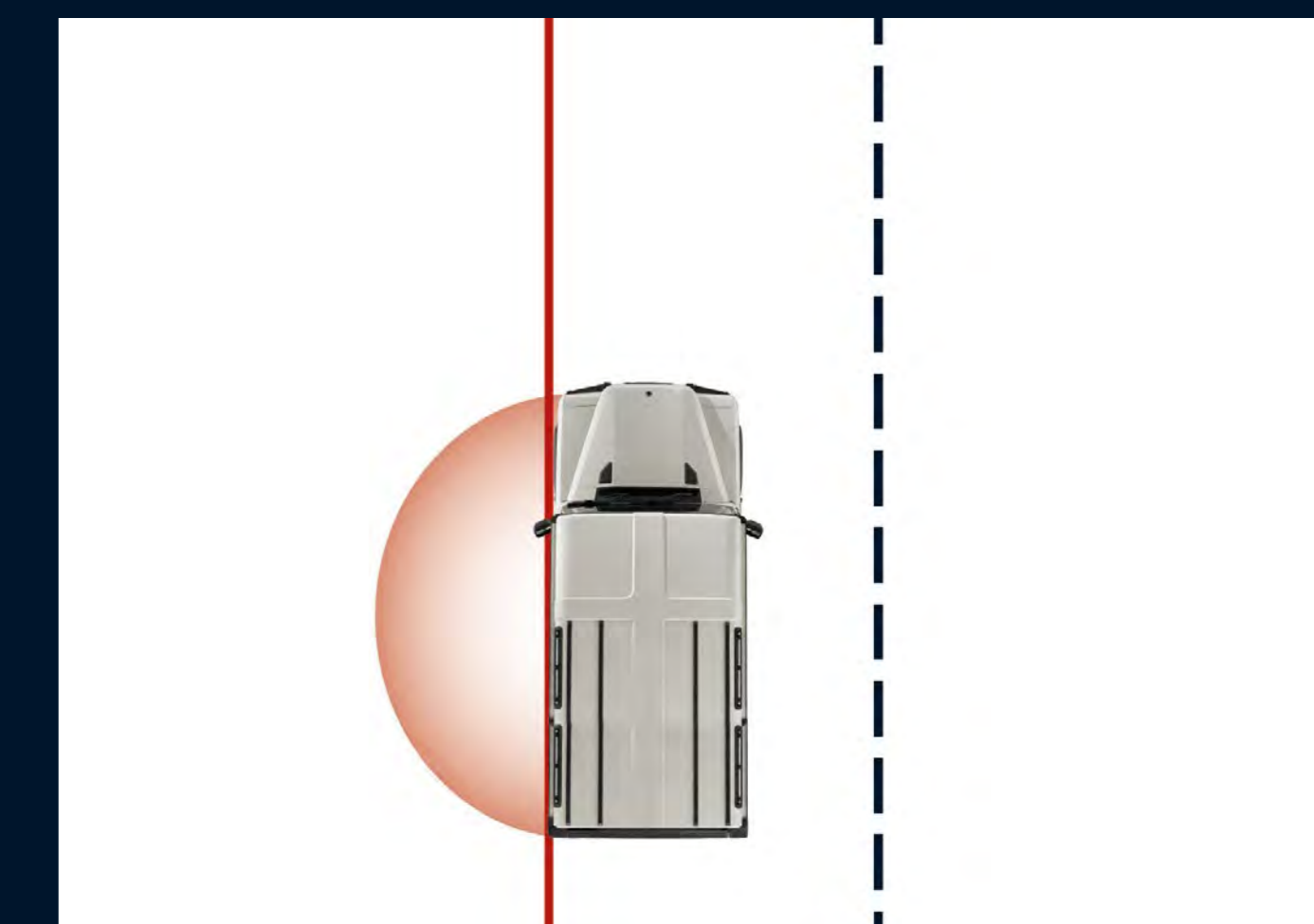

LANE DEPARTURE WARNING

Alerts the driver when they are too close to lane markings without using their turn signals, sending an audio-visual alert to the driver.

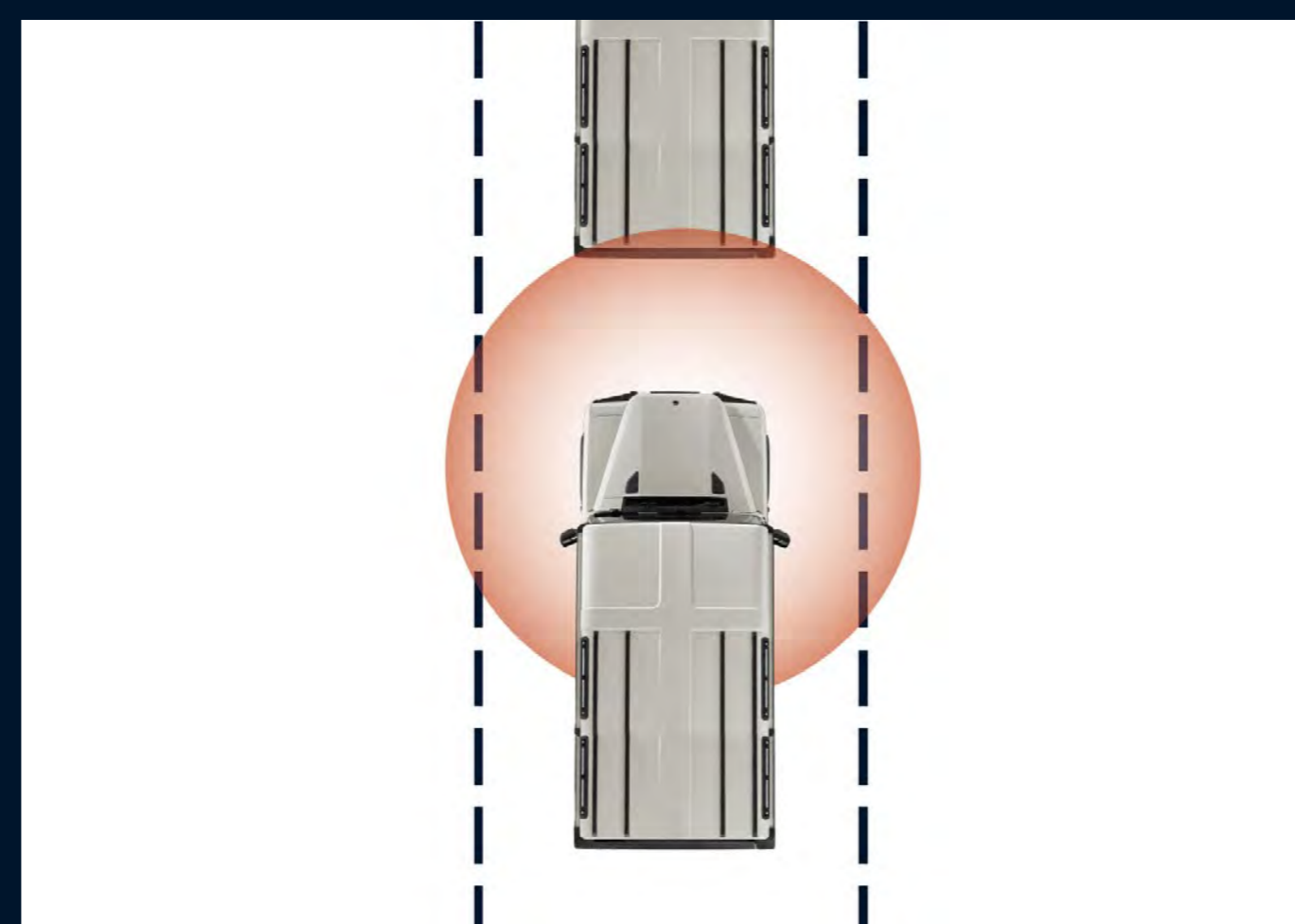

ADVANCED EMERGENCY BRAKING (AEB)

AEB monitors the vehicle's surroundings and may intervene and slow the vehicle without the driver's influence if it detects an imminent collision with certain road users.*

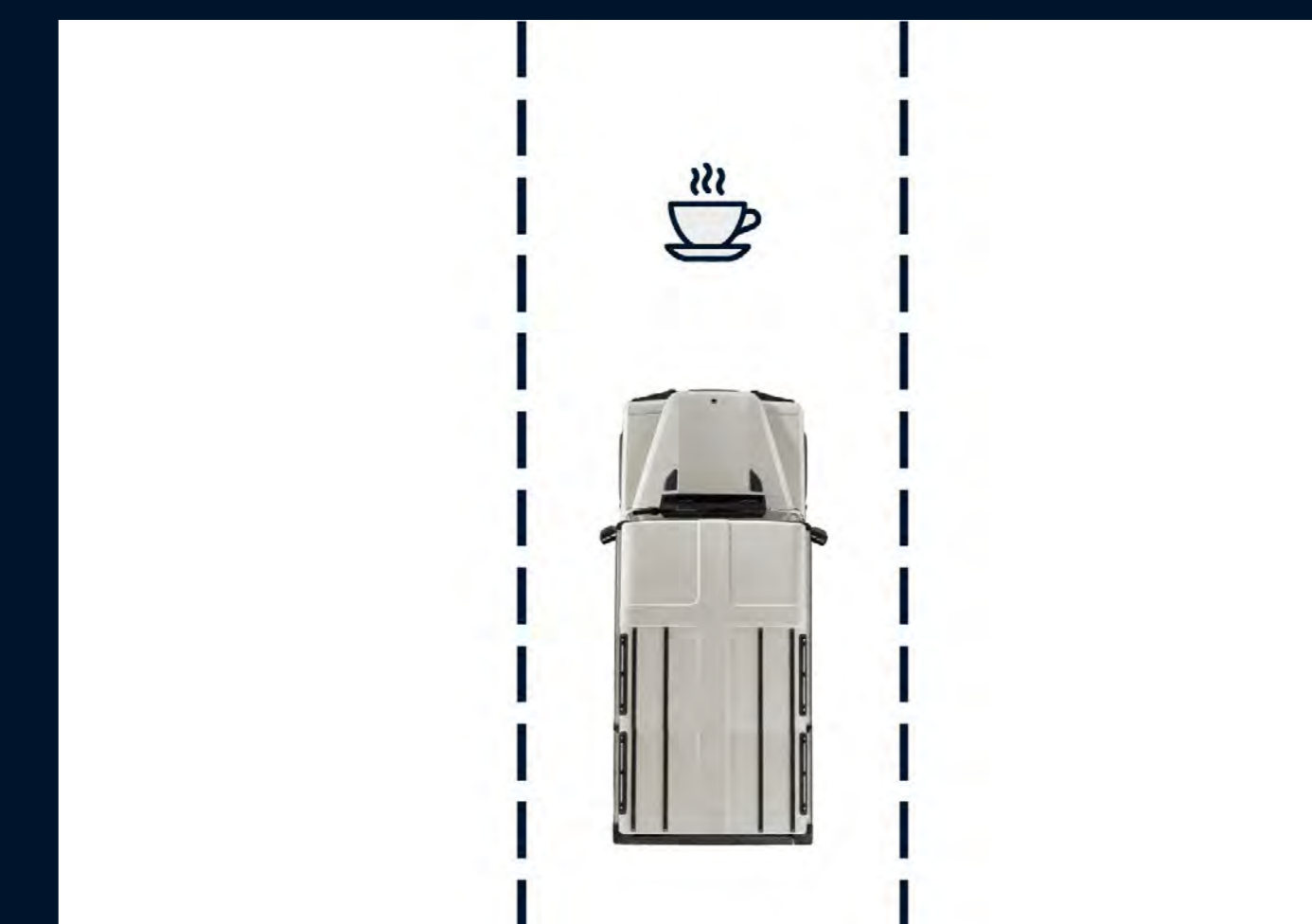

DRIVER DROWSINESS DETECTION

Monitors certain parameters for signals that the driver is drowsy and sends an audio-visual alert recommending that the driver takes a break.

Read the owners' manual for further information
 Performance of ADAS may be reduced due to weather, obstructions and/or damage interfering with sensors and cameras. It is intended as driver support only and the driver is responsible for full control of the vehicle in all situations.
 *System does not react to scooters, cyclists, pedestrians, and animals.
 Upon reaching Model Year 24, all Grenadier products (dependent on market) will have driver assistance systems as standard.



INEOS | GRENADIER

We believe the information and specifications in this brochure to be correct at the time of publishing. INEOS reserves the right to make changes at any time, without notice, in prices, colors, materials, equipment, specifications, models and availability. Your INEOS dealer is the best source of the most up-to-date information on Grenadier vehicles. Specifications, dimensions, measurements, ratings and other numbers in this brochure, on our website and other printed materials provided at the dealership or affixed to vehicles are approximations based on design and engineering drawings, prototypes and laboratory tests. Your vehicle may differ due to variations in manufacture and equipment. Since some information may have been updated since the time of publication, please check with your INEOS dealer for complete details. INEOS reserves the right to lengthen or shorten the model year for any product for any reason or to start and end model years at different times. Certain vehicle features may lose their usefulness over time due to obsolescence from technological changes. Optional features, accessories and their availability may differ by vehicle (bodystyle and powertrain) and country or require the installation of other features in order to be fitted. Note that some standard features may be replaced when specifying a vehicle or selecting trim levels. Please contact your local Retail Partner for more details or configure your vehicle online.

©2023 INEOS Automotive America, LLC. All rights reserved. INEOS and Grenadier, the logos, slogans, emblems, vehicle model names, vehicle body designs and other marks appearing in this brochure are the trademarks and/or service marks of INEOS Capital Limited, its subsidiaries, affiliates or licensors. Sirius, XM and all related marks and logos are trademarks of SiriusXM Radio, Inc. Google, Android, Android Auto and other marks are trademarks of Google LLC. Apple, CarPlay, iPhone and Siri are registered trademarks of Apple, Inc.

Warranty periods offered by INEOS on certain features may be limited and differ in duration. Please refer to the INEOS Automotive Manufacturers Warranty Terms and Conditions for details of variations and exceptions.

All tests are performed in accordance with legislation in force at the time of certification. EPA estimated fuel economy shown, these figures may not reflect real world driving conditions. Your mileage may vary depending on several factors including your driving habits, vehicle condition, weather conditions, vehicle load, options and accessories fitted and trip length.

All values are in US mpg	City	Highway	Combined
Grenadier Station Wagon	15 mpg	15 mpg	15 mpg
Grenadier Fieldmaster	15 mpg	15 mpg	15 mpg
Grenadier Trialmaster	14 mpg	14 mpg	14 mpg

Additional options offered for the vehicle may affect performance, emissions, exterior dimensions and off/on-road geometry. Loading equipment on the roof may change the vehicle's handling characteristics and users should not load the vehicle, any options or accessories (or any part of them) beyond their intended capacities.

Off-road driving and use of related equipment (including options and accessories) requires advanced training and experience. Improper use of the vehicle or other equipment may be unsafe and could result in property damage and/or injury to users and/or other parties. It is the user's responsibility to check the vehicle, equipment, route and conditions ahead before proceeding. Consult the Owner's Manual, applicable accessories manual/instructions or your closest Retail Partner for more detail.

The aniline saddle leather is untreated and is subject to staining and discoloration as it absorbs moisture and oils and will fade and/or discolor when exposed to the sun. Due to the nature of the material, we are unable to include the Saddle Leather Driver's Pack within our full vehicle warranty and cannot accept responsibility for any staining, fading, discoloration or any other defects typical of this leather type caused by natural wear or otherwise. By selecting the Saddle Leather Driver's Pack you acknowledge acceptance of the above information. Please refer to the Warranty T&Cs for more detail.

The Utility Belt option has restricted usage on-road, dependent on local laws.

Only use in-car features when safe to do so. Driving while distracted can result in loss of vehicle control, damage to property, injury or death. Always obey local laws and speed limits.

When used herein, "Retail Partner" shall mean any INEOS authorized dealer, agent, retail seller, importer, repairer or service provider.

The LED Light Bar only works with the 2024 INEOS Grenadier. Warning – this part has been designed and is intended for Off-Road Application Only, not for use on public roads. This part may not be installed by INEOS or an INEOS dealer, and may not be sold or financed in conjunction with the sale of a vehicle. INEOS Automotive Americas, LLC does not authorize and strictly prohibits the installation of any part designated as "Off-Road Application Only" by INEOS, an INEOS dealer or authorized repair provider. Installation and use of this part on a vehicle intended for use on public roads may violate U.S., Canadian, state or provincial laws and regulations, including those relating to emission requirements and motor vehicle safety standards. Such installation is solely the responsibility of the vehicle owner. The vehicle owner is responsible for using the part in compliance with federal, state, provincial and local laws. In addition, installation of this part may adversely affect the warranty coverage on your vehicle.

Prototype vehicle images included throughout. Some features may not be representative of final vehicle specifications.

All SiriusXM services require a subscription, sold separately by SiriusXM after the trial period. Your SiriusXM service will automatically stop at the end of your trial unless you decide to subscribe. If you decide to continue service, the subscription plan chosen will automatically renew and be charged according to your chosen payment method at the then-current rates. Fees and taxes apply. See the SiriusXM Customer Agreement & Privacy Policy at www.siriusxm.com for full terms and how to cancel, which includes online methods or calling 1-866-635-2349. Available in the 48 contiguous United States, D.C., and Puerto Rico (with coverage limits and capable receiver). Visit <http://www.siriusxm.com/FAQS> for most current service area information. Availability of some services and features is subject to device capabilities and location restrictions. All fees, content and features are subject to change. SiriusXM, Pandora and all related logos are trademarks of Sirius XM Radio Inc. and its respective subsidiaries.

²Vehicle will include 3-month trial subscription for SiriusXM. Your service will automatically stop at the end of your trial subscription unless you decide to continue service. If you decide to continue service after your trial period included with the new vehicle purchase, the subscription plan you choose will automatically renew thereafter and you will be charged according to your chosen payment method at then-current rates. Trial service is not transferable. Fees and taxes apply. Please see the Customer Agreement at www.siriusxm.com for complete terms and how to cancel, which includes online methods or calling SiriusXM at 1-866-635-2349. All fees, content and features are subject to change. Channel lineup varies by plan.